

! WARNING

**DISCONNECT POWER BEFORE RE-LAMPING OR WIRING THE FIXTURE
READ ALL INSTRUCTIONS COMPLETELY BEFORE STARTING INSTALLATION.**

! CAUTION

- TO AVOID THE RISK OF FIRE OR SHOCK, FIXTURE MUST BE INSTALLED IN COMPLIANCE WITH ALL APPLICABLE NATIONAL AND LOCAL ELECTRICAL/BUILDING CODES.
- INSTALLATION AND MAINTENANCE OF THIS UNIT REQUIRES AN ELECTRICIAN OR CERTIFIED FACTORY TRAINED TECHNICIAN.
- If an existing fixture is being replaced, remove it and note to which of the wires in the junction box the fixture was attached. DO NOT SEPARATE ANY OTHER WIRES THAT MAY BE IN THE BOX. DO NOT DAMAGE THE INSULATION OF OLDER WIRING. In regular circumstances the BLACK wire will be the "Hot" lead and the WHITE wire will be the "Neutral" or "Common" lead A GREEN or BARE COPPER wire is the "Ground". In older buildings it is always good practice to reconfirm the polarity of the wiring.

NOTICE

- The important safeguards and instructions outlined on this sheet cannot cover all possible conditions and situations that may occur. it must be understood that common sense, caution and care factors that cannot be built into any product. Caution and care must be supplied by the person(s) installing, operating and caring of this lighting fixture.
- This fixture is designed to be mounted on a correctly installed standard round or octagon box or a through wiring box with a plaster frame. The box must be securely mounted to the structure of the building. The mounting ring with wing and hardware supplied should be used. directly mounting the fixture to the junction box may make it impossible to correctly align the fixture.

NOTICE:

CALIFORNIA PROP 65: THIS LIGHTING FIXTURE CONTAINS CHEMICALS KNOWN TO THE STATE OF CALIFORNIA TO CAUSE CANCER, BIRTH DEFECTS, AND/OR OTHER REPRODUCTIVE HARM. WASH HANDS AFTER USE.

FIXTURE PREPARATION

1. Remove the fixture, parts and parts bag(s) from the carton.

NOTICE:

- Before discarding the carton, double check to make certain that all parts are found.

2. Remove the oval ring, nylon washer and ball nuts by unthreading the ball nuts from the fixture. (SEE FIGURE-01)

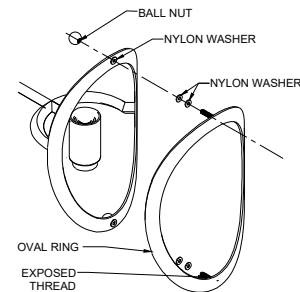

FIGURE-01

FIXTURE INSTALLATION

1. Attach the mounting ring with wing to the junction box. (The green screw should face the floor). (SEE FIGURE-02)
2. Fasten the ground wire to the green or bare copper wire in the junction box of the green screw on the heavy duty strap.

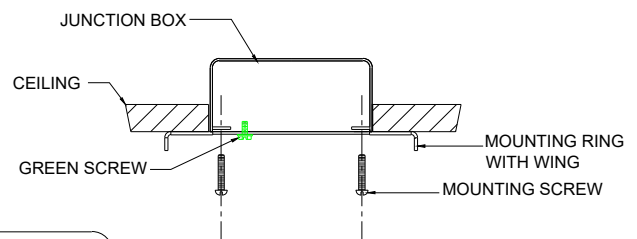

FIGURE-02

! WARNING

**Never fasten the ground wire to the black or "hot" wire!
Failure to follow this instruction could result in serious injury or death!**

3. Fasten the white fixture lead to the white wire in the junction box. Fasten the wires together with an approved fastener (wire nut). Starting about 1" below the fastener, tightly wrap the connection with electrical tape so that the connections seals the end of the fastener.

⚠ WARNING
 Make sure that there is no exposed wire or strands that could cause a dangerous short circuit!

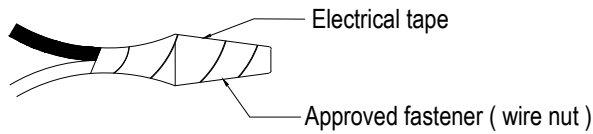

4. Connect the black fixture lead to the black wire in the junction box. Fasten the joined wires as in step 3.
5. Pull up & attach the fixture to the mounting ring with wing using flat head screws. (SEE FIGURE-03)
6. Place the bulb into the socket of the fixture. (SEE FIGURE-04)

NOTICE:
 This fixture is rated for 60w TYPE-B.

⚠ WARNING
 DO NOT EXCEED RECOMMENDED WATTAGE!

7. Install the glass on each arm of the fixture by inserting the exposed thread of the oval ring through the glass and onto the fixture, and secure it with ball nuts. **NOTICE:** Nylon washer must be used between each sides of the glass holes as seen in the figure. (SEE FIGURE-05)

8. Restore power to the circuit breaker or fuse box.

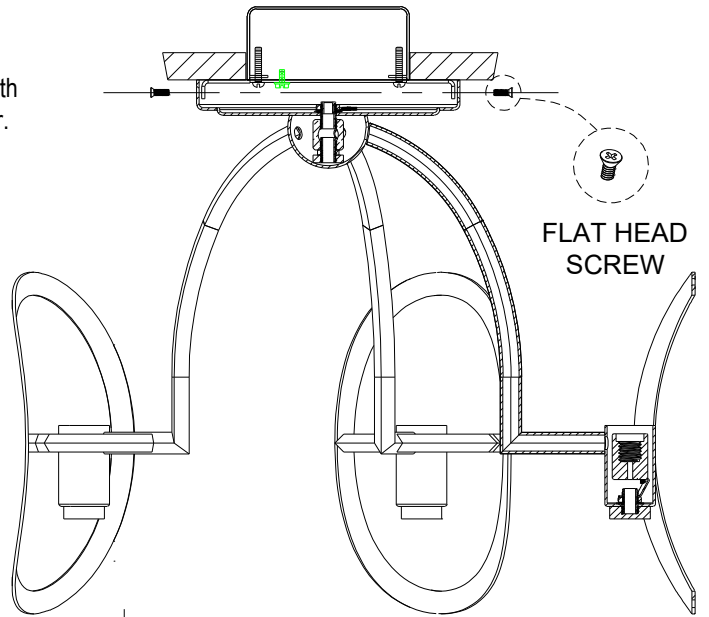

FIGURE-03

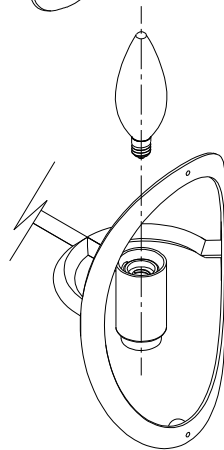

FIGURE-04

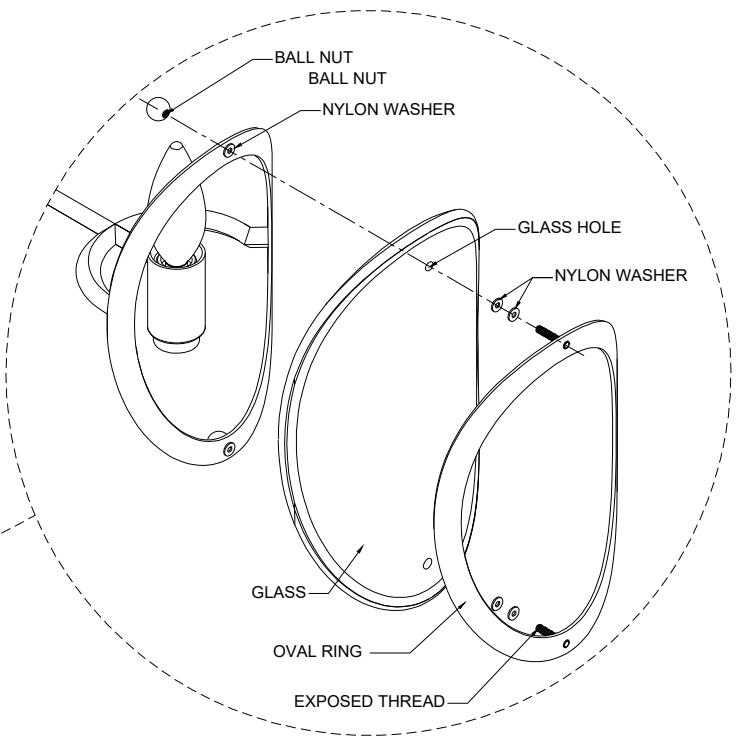
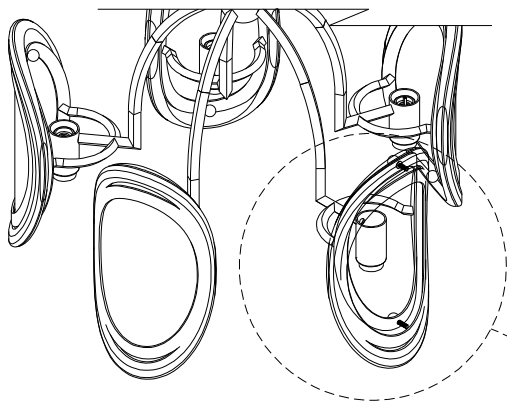
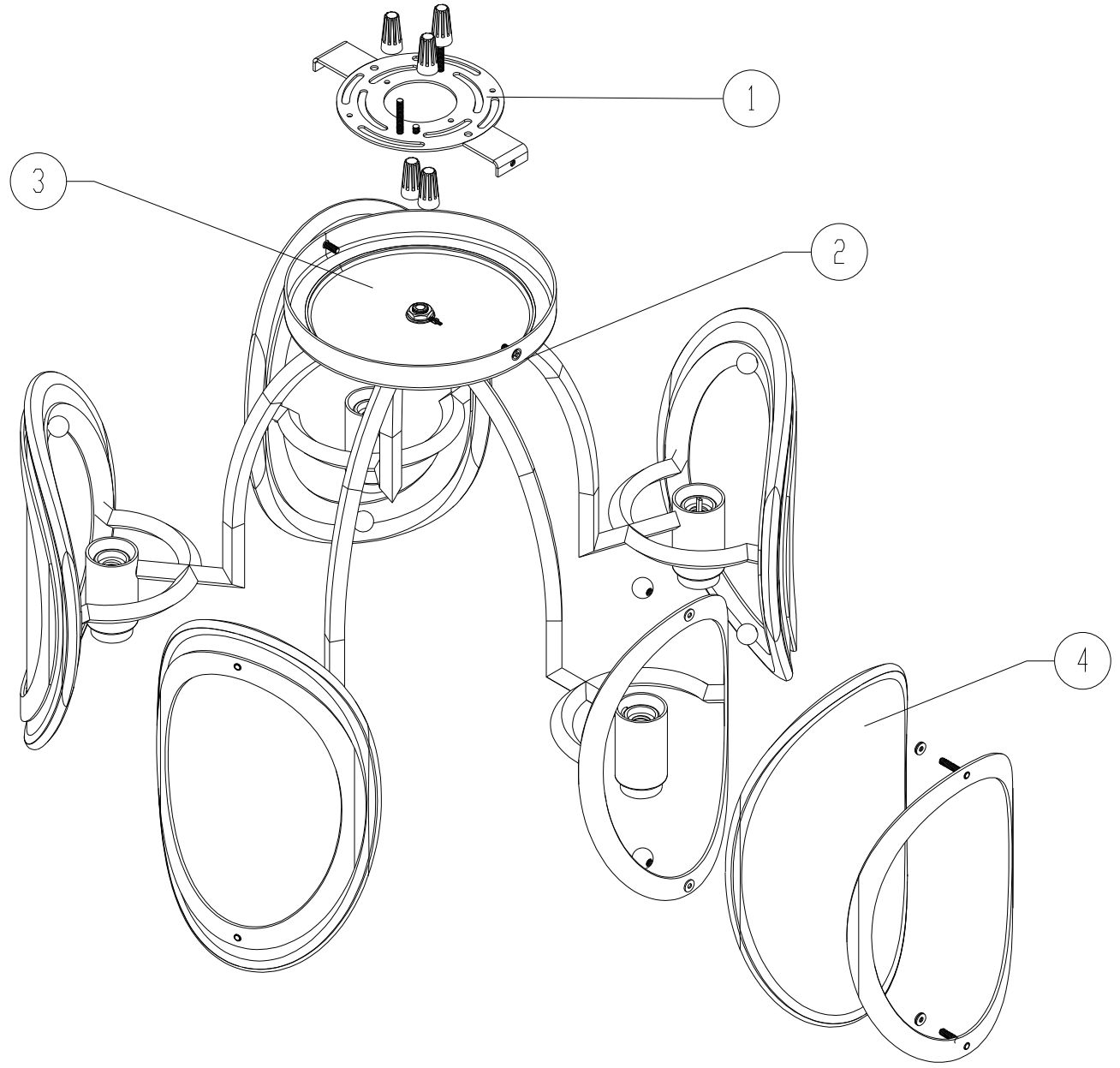

FIGURE-05

PARTS LIST 1520

ITEM NUMBER	PART NUMBER	DESCRIPTION
1	R-VX35-HRD	MOUNTING HARDWARE
2	R-VX35-FRM	FRAME
3	R-VX35-CPY	CANOPY
4	R-VX35-GCT	GLASS



! ATTENTION

DÉBRANCHEZ L'ALIMENTATION AVANT DE REMPLIR OU DE CÂBLER LE LUMINAIRE
LISEZ COMPLÈTEMENT TOUTES LES INSTRUCTIONS AVANT DE COMMENCER L'INSTALLATION.

! AVERTIR

- POUR ÉVITER LES RISQUES D'INCENDIE OU D'ÉLECTROCUTION, LE LUMINAIRE DOIT ÊTRE INSTALLÉ CONFORMÉMENT TOUS LES CODES NATIONAUX ET LOCAUX APPLICABLES EN MATIÈRE D'ÉLECTRICITÉ ET DE CONSTRUCTION.
- L'INSTALLATION ET L'ENTRETIEN DE CET APPAREIL NÉCESSITENT UN ÉLECTRICIEN OU TECHNICIEN CERTIFIÉ FORMÉ EN USINE.
- Si un luminaire existant est remplacé, retirez-le et notez à quel fil de la boîte de jonction le luminaire était attaché. **NE SÉPAREZ AUCUN AUTRE FIL PEUVENT ÊTRE DANS LA BOÎTE. N'ENDOMMAGEZ PAS L'ISOLATION DE L'ANCIEN CÂBLAGE.** Dans des circonstances normales, le fil NOIR sera le fil "chaud" et le fil BLANC sera le fil "neutre" ou "commun" Un fil VERT ou CUIVRE NU est la "Masse". Dans les bâtiments plus anciens, il est toujours recommandé de reconfirmer la polarité du câblage.

AVIS

- Les garanties et instructions importantes décrites sur cette fiche ne peuvent pas couvrir toutes les conditions et situations possibles qui peut se produire. il faut comprendre que le bon sens, la prudence et les soins sont des facteurs qui ne peuvent être intégrés à aucun produit. La prudence et les soins doivent être fournis par la ou les personnes qui installent, utilisent et entretiennent cet appareil d'éclairage.
- Ce luminaire est conçu pour être monté sur une boîte ronde ou octogonale standard correctement installée ou une boîte de câblage traversante avec un cadre en plâtre. La boîte doit être solidement fixée à la structure du bâtiment. La barre transversale et la quincaillerie fourni doit être utilisé. le montage direct du luminaire sur la boîte de jonction peut rendre impossible l'alignement correct du luminaire.

AVIS:
CALIFORNIE PROP 65 : CET APPAREIL D'ÉCLAIRAGE CONTIENT DES PRODUITS CHIMIQUES CONNUS PAR L'ÉTAT DE CALIFORNIE POUR PROVOQUER LE CANCER, DES MALADIES CONGÉNITALES ET/OU D'AUTRES DOMMAGES À LA REPRODUCTION. LAVER LES MAINS PRÈS UTILISATION.

FIXTURE PREPARATION

1. Remove the fixture, parts and parts bag(s) from the carton.

NOTICE:

- Before discarding the carton, double check to make certain that all parts are found.

2. Remove the oval ring, nylon washer and ball nuts by unthreading the ball nuts from the fixture. (SEE FIGURE-01)

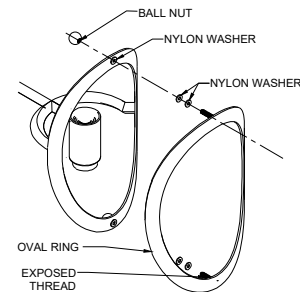

FIGURE-01

FIXTURE INSTALLATION

1. Attach the mounting ring with wing to the junction box. (The green screw should face the floor). (SEE FIGURE-02)
2. Fasten the ground wire to the green or bare copper wire in the junction box of the green screw on the heavy duty strap.

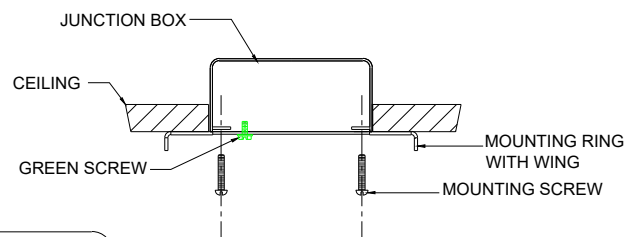

FIGURE-02

! WARNING

Never fasten the ground wire to the black or "hot" wire!
Failure to follow this instruction could result in serious injury or death!

3. Fasten the white fixture lead to the white wire in the junction box. Fasten the wires together with an approved fastener (wire nut). Starting about 1" below the fastener, tightly wrap the connection with electrical tape so that the connections seals the end of the fastener.

⚠ WARNING
Make sure that there is no exposed wire or strands that could cause a dangerous short circuit!

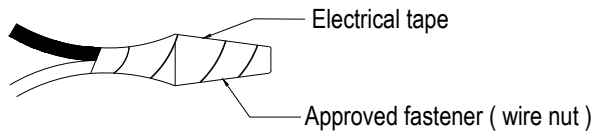

4. Connect the black fixture lead to the black wire in the junction box. Fasten the joined wires as in step 3.
5. Pull up & attach the fixture to the mounting ring with wing using flat head screws. (SEE FIGURE-03)
6. Place the bulb into the socket of the fixture. (SEE FIGURE-04)

NOTICE:
 This fixture is rated for 60w TYPE-B.

⚠ WARNING
DO NOT EXCEED RECOMMENDED WATTAGE!

7. Install the glass on each arm of the fixture by inserting the exposed thread of the oval ring through the glass and onto the fixture, and secure it with ball nuts. **NOTICE:** Nylon washer must be used between each sides of the glass holes as seen in the figure. (SEE FIGURE-05)

8. Restore power to the circuit breaker or fuse box.

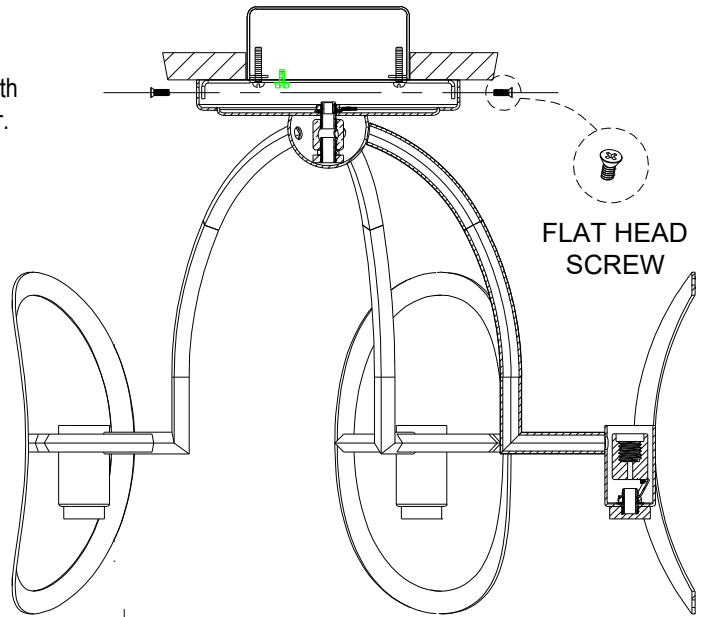

FIGURE-03

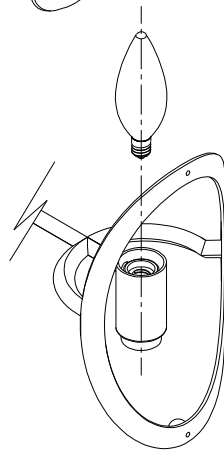

FIGURE-04

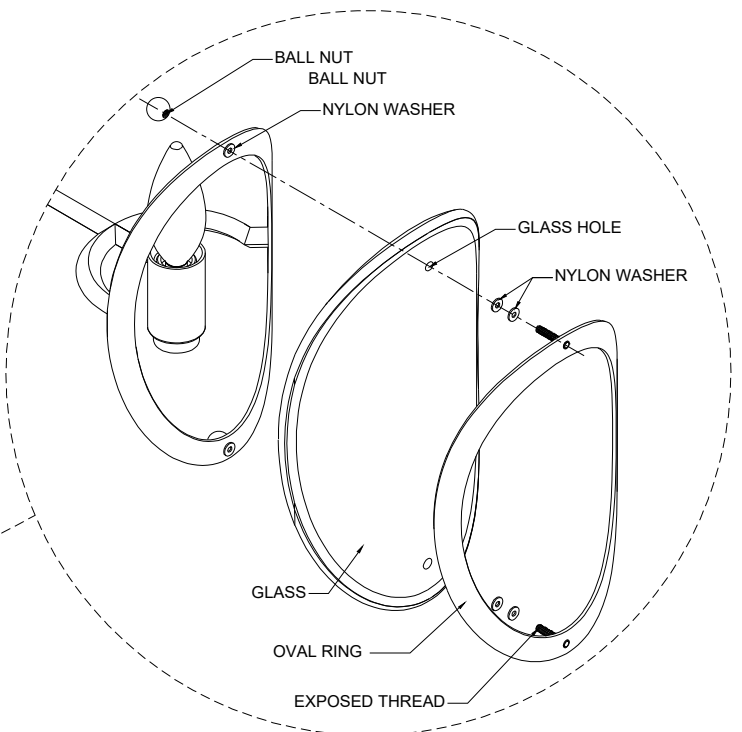
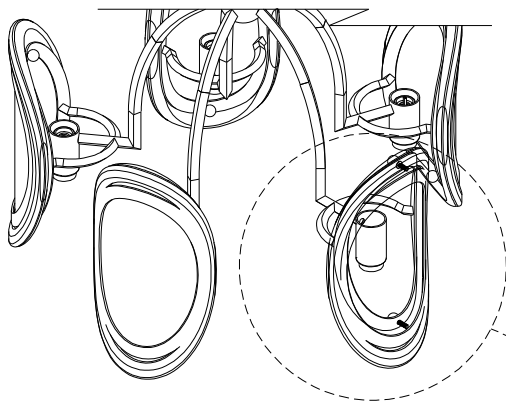

FIGURE-05

PARTS LIST 1520

ITEM NUMBER	PART NUMBER	DESCRIPTION
1	R-VX35-HRD	MOUNTING HARDWARE
2	R-VX35-FRM	FRAME
3	R-VX35-CPY	CANOPY
4	R-VX35-GCT	GLASS

